

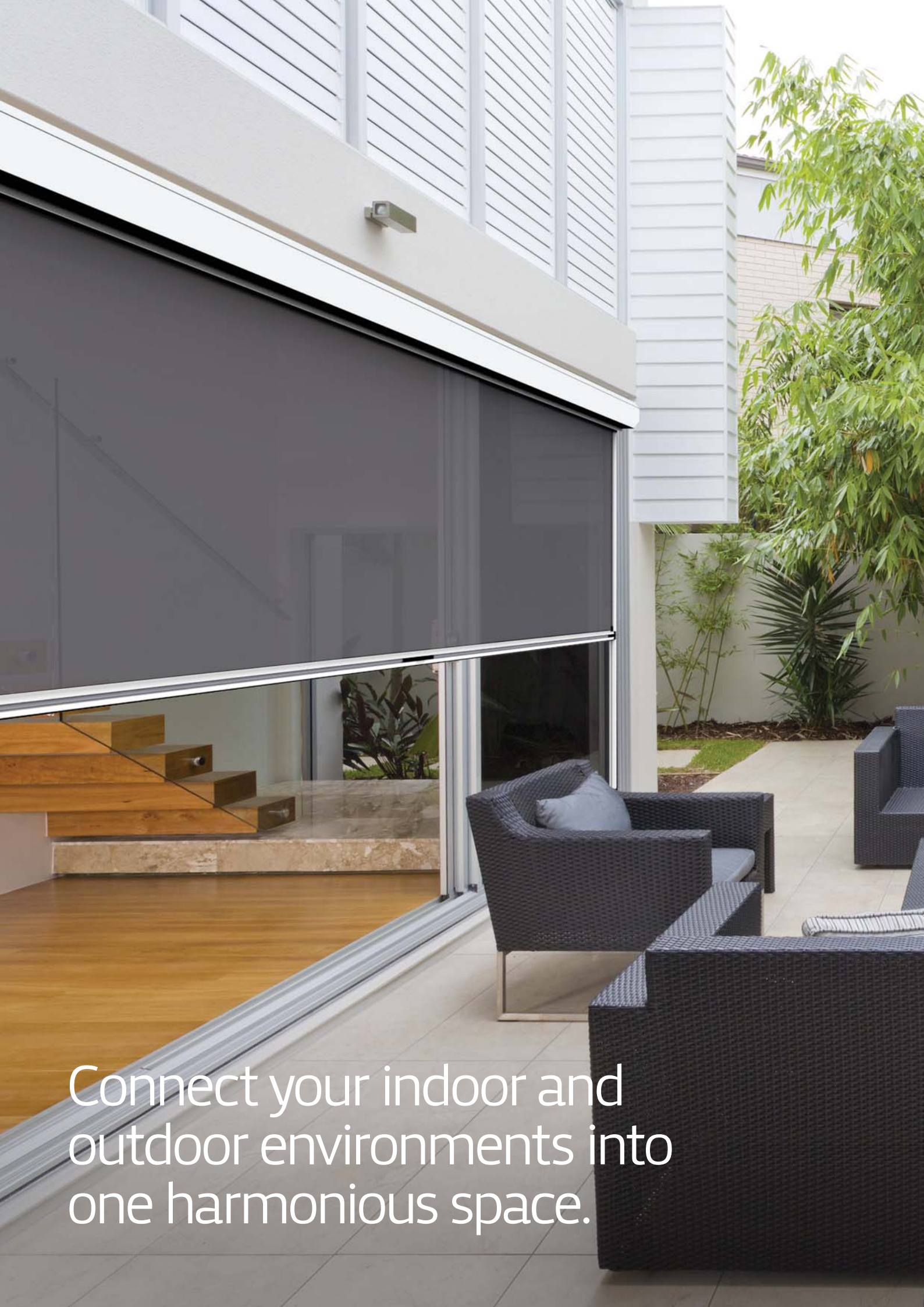

AUSTRALIA'S FAVOURITE TRACK-GUIDED BLIND SYSTEM



The trusted outdoor living solution



Connect your indoor and outdoor environments into one harmonious space.



Ziptrak® Sunscreen Mesh blind with white pelmet.

Instantly transform your space to create a sense of seclusion and sanctuary. You'll spend more time enjoying life outdoors with family and friends.

Offering protection during every season from UV, sun, wind, and rain for year-round outdoor entertaining.

Ziptrak® is the original and trusted track guided blind system with a patented design that glides smoothly and stops at any height.

The trusted solution for outdoor protection.

Add another room to your home.

Australian owned and invented.

Custom made for every installation.



The blind glides smoothly and can be left at any height.



Fast and easy operation.

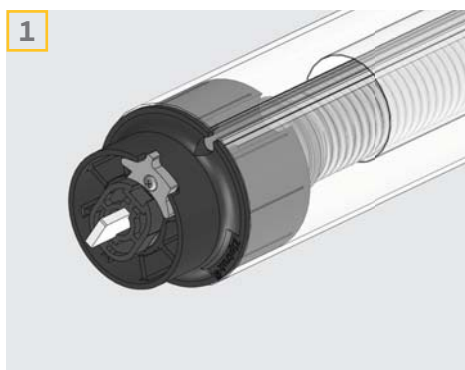

SPRING-BALANCED

The unique spring-balanced system provides lightweight hand operation.

Intuitive and easy to use.

No crank, chains, zips or cords.

Leave at any height.



CENTRE-LOCK-RELEASE

The patented Ziptrak® system is even easier to use with the unique Centre-Lock-Release. The blinds lock at their lowest position providing a secure hold in the high winds. When you are ready to open again, simply lift the handle to activate release latches on both sides of the bottom bar.

Yet another remarkable and intuitive solution that makes outdoor entertaining a pleasure.

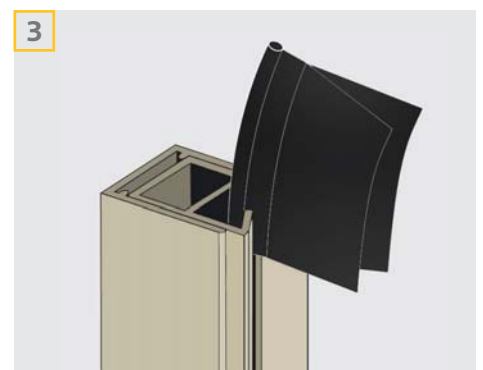

TRACK-GUIDED

Most outdoor blinds have gaps which let in dust, wind, rain and insects. Ziptrak® provides a sealed barrier, keeping out heat during summer, but locking in the warmth during winter.



SUN AND UV PROTECTION



WIND AND RAIN PROTECTION



MANUAL OR ELECTRIC OPERATION

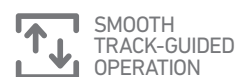

SMOOTH TRACK-GUIDED OPERATION

Design your blind.

Patented system.

100% Australian made and owned.

Robust and durable materials.

Custom made every time.

CAST BRACKET

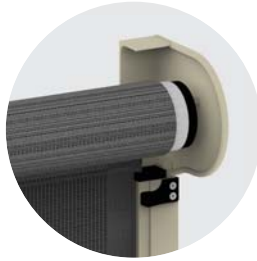

CAST BRACKET WITH BACK FLASHING

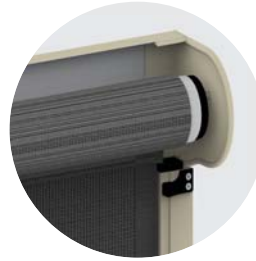

PELMET



HARDWARE COLOUR RANGE

Ziptrak® aluminium componentry is readily available in 5 different popular Colourbond® colours, or you can powder-coat to any conceivable colour.

Match or compliment your existing structure with customised colour options for the vertical tracks, bottom bar and pelmet.

Each blind system is custom measured, made and installed to your exact requirements.

PAPERBARK



CLASSIC CREAM



WOODLAND GREY



WHITE



BLACK



SUNSCREEN MESH

Available in a wide range of colours and transparencies.

Up to 99% UV block.

Up to 96% wind and rain block.

Significantly reduces sun glare.

Allows airflow.

Fresh outdoor feeling without being bothered by windy conditions.

Provides high degree of privacy during the day.

Easy-to-maintain material; looks great for years and requires infrequent cleaning.

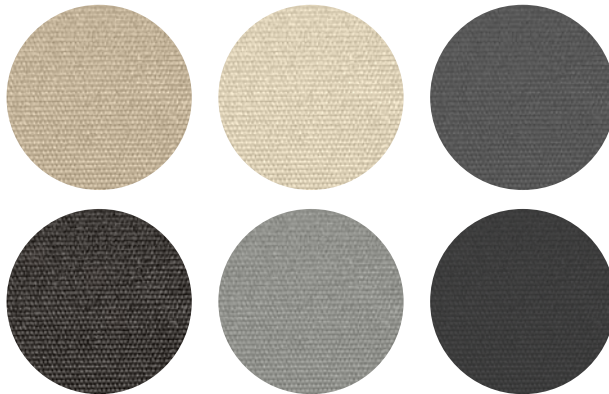

ASK YOUR
RETAILER
FOR MORE
INFORMATION

PVC

Available in clear or tinted.

Highly engineered plastic made specifically for outdoor blinds in Australia's harsh climate.

Provides complete blockout of wind, dust, rain and debris.

Completely see through for uninterrupted views.

Is the best material choice to maintain the temperature within the space.

Up to 93% UV Block.

CLEAR PVC



TINTED PVC



Sunscreen Mesh and PVC products are complimentary to the Ziptrak® system, but are not sold by Ziptrak Pty Ltd. Please speak with your retailer about the range, warranty and specifications of these products. We recommend making all selections upon seeing an actual sample. Varying light conditions and the printing process can affect colour tones displayed in this catalogue.



Expand your space.

Tough and durable for years of commercial use.

Ziptrak® blinds with unique combination of PVC and Sunscreen Mesh.



MOTORISATION

Optional motorisation is a popular choice for many household and commercial applications. The motor is hidden within the pelmet, and the blind can be left at any height. Motorisation is perfect for:

Large blinds.

One touch convenience.

Blinds mounted in hard-to-reach locations.

Lowering multiple blinds with one button.

People with limited mobility.

Only available with Sunscreen Mesh.



SOLARSMART™

SolarSmart™ allows you to operate your motorised Ziptrak® blinds without the need for an electrician to hard-wire into your building power. You'll have your blinds motorised sooner, and at a lower cost.



PROTECTIVE PELMET

A pelmet ensures the blind looks great and operates flawlessly for years.

Available in steel or rust-free aluminium.

Hides and protects blind.

Blocks weather.

Stylish design.

Australia's favourite track-guided blind system.

DIMENSIONS

Ziptrak® blinds are custom made to suit your requirements, for a secure and seamless installation. The system can cover wide spans to reduce the need for additional vertical supports, and provide uninterrupted views.

If you have a wider opening, talk with your retailer about the inclusion of a Ziptrak® Removable Post, or standard fixed post.

Up to 3.5m high

Up to 6m wide

Your local Ziptrak® expert is:

SHEERVIEW

WINDOW FURNISHINGS

141 Maudsland Rd Oxenford QLD

Ph: (07) 5580 0600

OPENING HOURS: MON – FRI – 8AM – 4PM



1300 77 00 65

enquiry@ziptrak.com.au

www.ziptrak.com.au



Ziptrak Pty Ltd is an Australian owned and operated business providing innovative outdoor living solutions since 2002. We know Australian homes and pride ourselves in the design and manufacture of our products.

© Ziptrak Pty Ltd 2015. Ziptrak® Registered Trade Mark of Ziptrak Pty Ltd. (100% Australian Owned).